

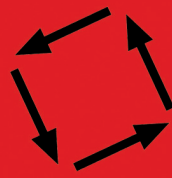

FABBRICA MACCHINE BERGAMO

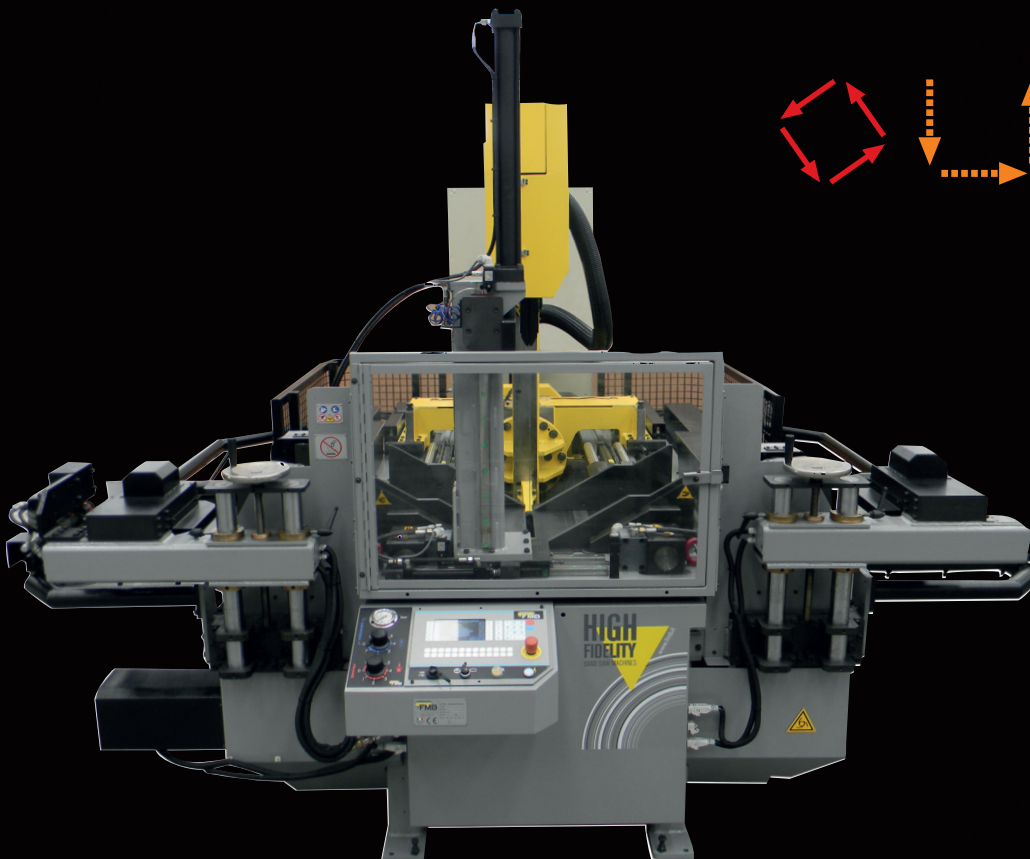

SEGATRICI A NASTRO
BAND SAW MACHINES • SCIÉS A RUBAN

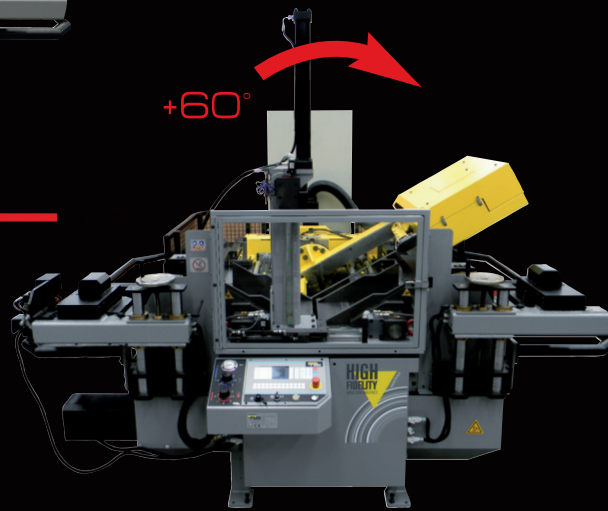

SCORPIO CNC
AUTOMATICA • AUTOMATIC • AUTOMATIQUES

10/2014



SCORP

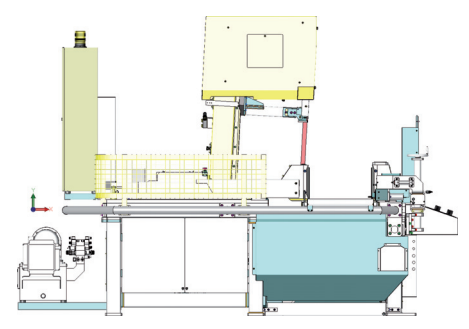
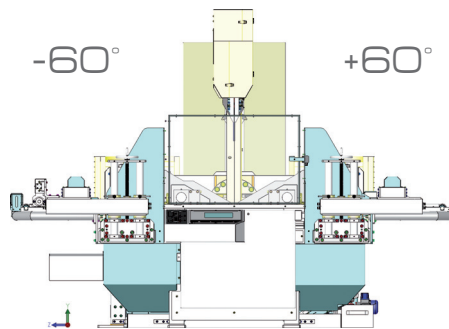
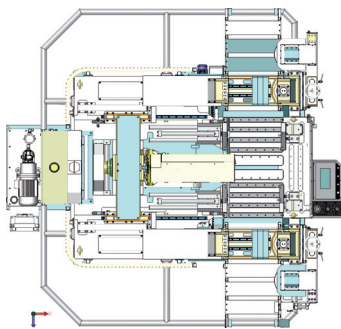
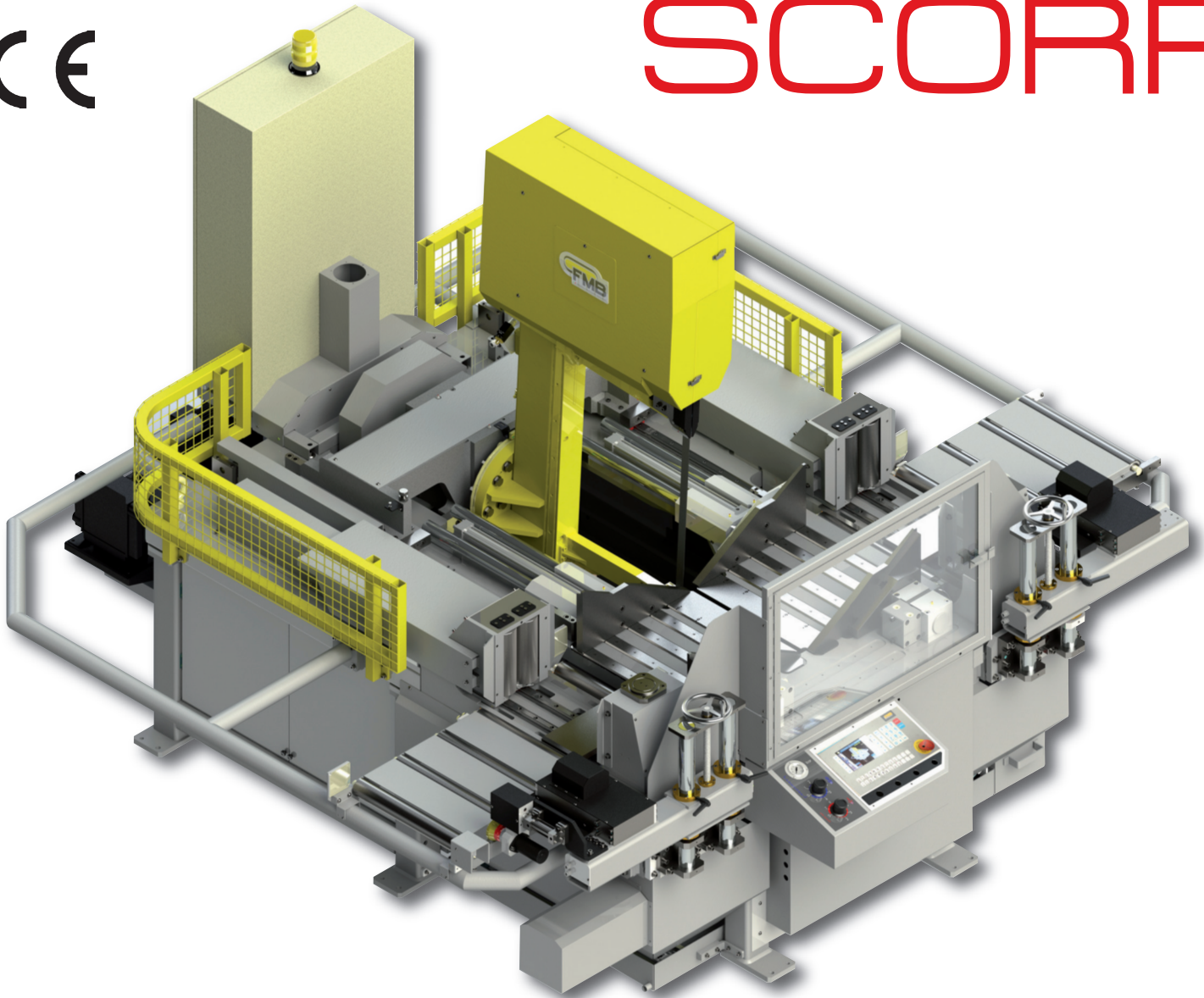







CAPACITÀ DI TAGLIO
CUTTING CAPACITY • CAPACITÉ DE COUPE

	● Ø mm / Inch	a ■ b a x b mm / Inch	a ■ b a x b mm / Inch	a ■ b a x b mm / Inch
0°	510 / 20	510 / 20	- / -	635x510 / 25x20
45° →	435 / 17 1/8	435 / 17 1/8	435x510 / 17 1/8x20	- / -
60° →	300 / 11 13/16	300 / 11 13/16	300x510 / 11 13/16x20	- / -
45° ←	435 / 17 1/8	435 / 17 1/8	435x510 / 17 1/8x20	- / -
60° ←	300 / 11 13/16	300 / 11 13/16	300x510 / 11 13/16x20	- / -

IO CNC

CARATTERISTICHE TECNICHE

TECHNICAL CHARACTERISTICS • CARACTÉRISTIQUES TECHNIQUES

 mm	 m/1'	 HP/KW	 HP/KW	 KG	 a x b x c m	 h±10 mm
5334X34X1,1	16÷120	5.4 4	5.4 4	6800	3,5x3,7x2,7	975

STANDARD

SENS
ST
NB1 BOX
TI

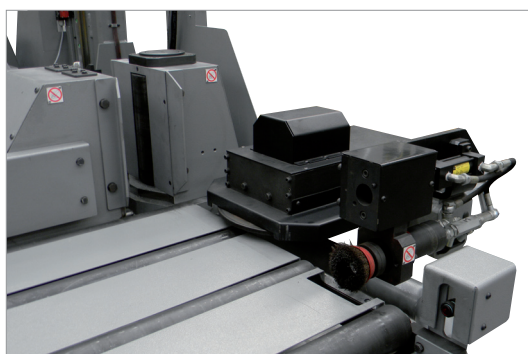

ST



NB1 BOX

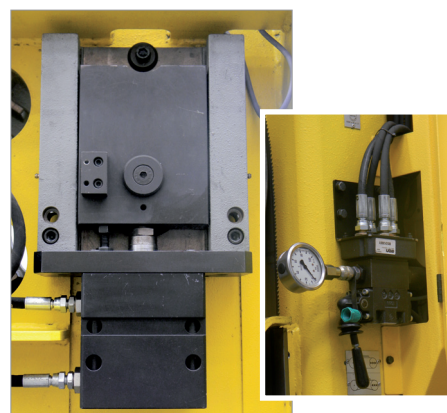

TI

OPTIONAL



PVS

PVS
Premitore verticale
Vertical clamping
Serrage vertical



DLC

DLC
Lubrificazione centralizzata
Centralized lubrication
Lubrification centralisée

F.M.B. si riserva il diritto di modificare i dati indicati senza necessità di preavviso. - F.M.B. srl se réserve d'apporter toutes modifications quelconque sans aucun préavis.

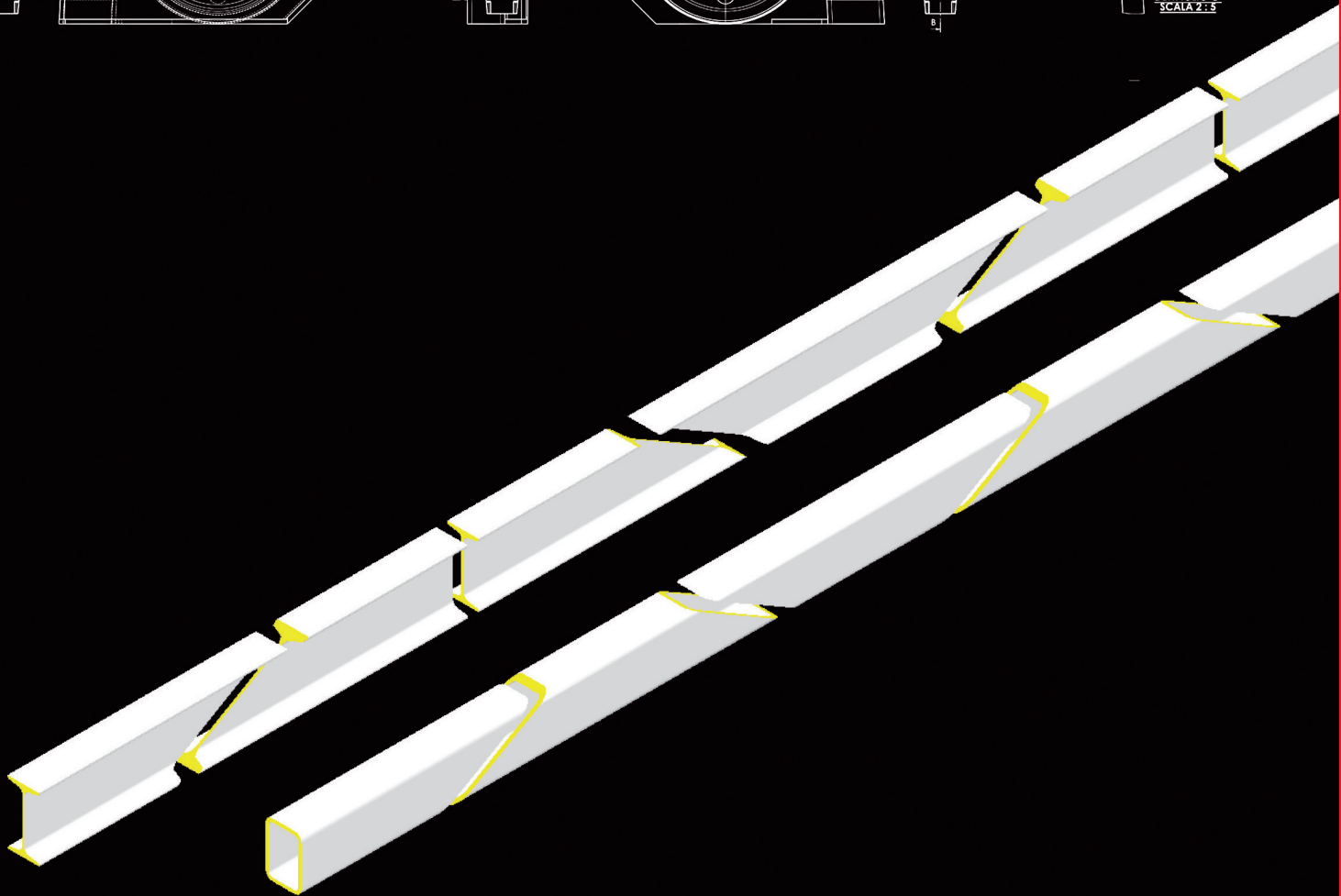
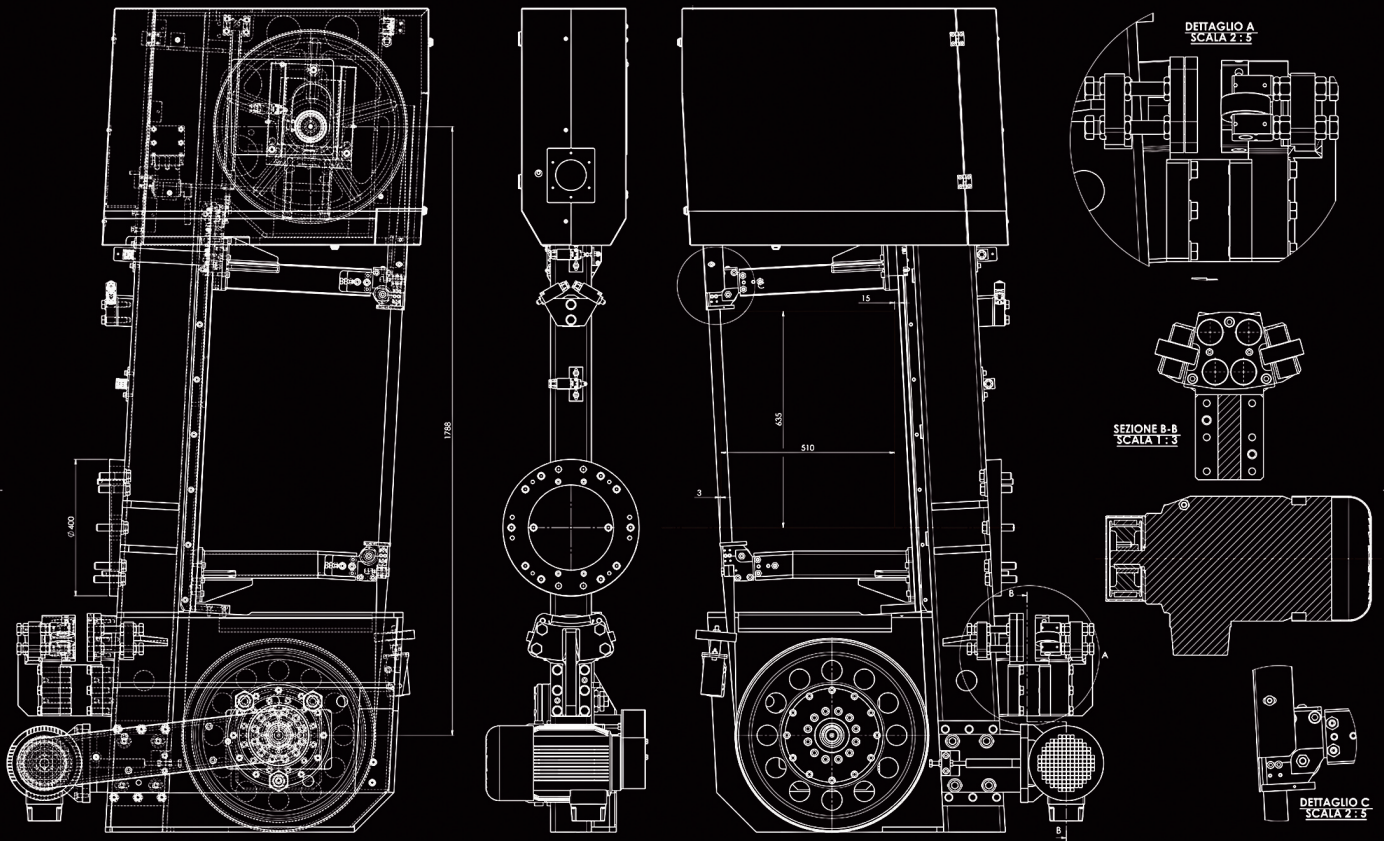

F.M.B. SRL - Via Lodi 7 - 24044 DALMINE (BG) - ITALY
 Tel. +39 035 370555 - Fax +39 035 370668
 E-mail info@fmb.it - www.fmb.it